

Emerson[®]

HOME AUDIO SYSTEM
with CD PLAYER
and CASSETTE RECORDER

OWNER'S MANUAL

MS7622

Visit our web site at www.emersonradio.com



CAUTION

TO PREVENT FIRE OR SHOCK HAZARD, DO NOT USE THIS PLUG WITH AN EXTENSION CORD, RECEPTACLE OR OTHER OUTLET UNLESS THE BLADES CAN BE FULLY INSERTED TO PREVENT BLADE EXPOSURE. TO PREVENT FIRE OR SHOCK HAZARD, DO NOT EXPOSE THIS APPLIANCE TO RAIN OR MOISTURE.



The lightning flash with arrow-head symbol, within an equilateral triangle is intended to alert the user to the presence of uninsulated 'dangerous voltage' within the product's enclosure that may be of sufficient magnitude to constitute a risk of electric shock to persons.

CAUTION

RISK OF ELECTRIC SHOCK
DO NOT OPEN

WARNING: TO REDUCE THE RISK OF ELECTRIC SHOCK DO NOT REMOVE COVER (OR BACK), NO USER SERVICEABLE PARTS INSIDE REFER SERVICING TO QUALIFIED SERVICE PERSONNEL.



The exclamation point within an equilateral triangle is intended to alert the user to the presence of important operating and maintenance (servicing) instructions in the literature accompanying the appliance.

IMPORTANT SAFETY INSTRUCTIONS

- 1.) Read these instructions.
- 2.) Keep these instructions.
- 3.) Heed all warnings.
- 4.) Follow all instructions.
- 5.) Do not use this apparatus near water.
- 6.) Clean only with dry cloth.
- 7.) Do not block any ventilation openings. Install in accordance with the manufacturer's instructions.
- 8.) Do not install near any heat sources such as radiators, heat registers, stoves, or other apparatus (including amplifiers) that produce heat.
- 9.) Do not defeat the safety purpose of the polarized or grounding-type plug. A polarized plug has two blades with one wider than the other. A grounding type plug has two blades and a third grounding prong. The wide blade or the third prong is provided for your safety. If the provided plug does not fit into your outlet, consult an electrician for replacement of the obsolete outlet.
- 10.) Protect the power cord from being walked on or pinched particularly at plugs, convenience receptacles, and the point where they exit from the apparatus.
- 11.) Only use attachments / accessories specified by the manufacturer.
- 12.) Unplug this apparatus during lightning storms or when unused for long periods of time.
- 13.) Refer all servicing to qualified service personnel. Servicing is required when the apparatus has been damaged in any way, such as power-supply cord or plug is damaged, liquid has been spilled or objects have fallen into the apparatus, the apparatus has been exposed to rain or moisture, does not operate normally, or has been dropped.
- 14.) This appliance shall not be exposed to dripping or splashing water and no object filled with liquids such as vases shall be placed on the apparatus.
- 15.) Do not overload wall outlet. Use only power source as indicated.
- 16.) Use replacement parts as specified by the manufacturer.
- 17.) The product may be mounted to a wall only if recommended by the manufacturer.
- 18.) Upon completion of any service or repairs to this product, ask the service technician to perform safety checks.

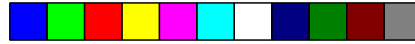

Thank you.....for purchasing this Emerson audio product. The Emerson brand is your assurance of quality, performance and value.

Our engineers have included many useful and convenient features in this product. Please be sure to read this Owner's Manual completely to make sure you are getting the maximum benefit from each feature.

This product was manufactured using the highest quality components and standards of workmanship. It was tested by Emerson inspectors and found to be in perfect working order before it left our factory. However, there is always the chance that some problem may occur because of rough handling during shipment to the retail store or to the final consumer.

If, after reading this manual, you experience any problems with the operation of this product, please refer to the instructions for obtaining service at the end of this manual. Emerson and Emerson retailers are committed to your satisfaction.

Once again, thanks for purchasing this Emerson audio product.

For future reference, record the serial number in the space provided.

Model No: MS7622

Serial No: _____



IMPORTANT NOTES

- Avoid installing this unit in places exposed to direct sunlight or close to heat radiating appliances such as electric heaters, on top of other stereo equipment that radiates too much heat, places lacking ventilation or dusty areas, places subject to constant vibration and/or humid or moist areas.
- Do not attempt to clean this unit with chemical solvents as this might damage the finish. Use a clean dry cloth.
- Operate controls and switches as described in the manual.
- Before turning 'On' the power, make certain that power cord is properly installed.
- Store your CDs, cassettes in a cool area to avoid damage from heat.
- When moving the set, be sure to first disconnect the power cord.

CLASS 1 LASER PRODUCT

CLASS 1 LASER PRODUCT
APPAREIL À LASER DE CLASSE 1
PRODUCTO LASER DE CLASE 1

CAUTION
INVISIBLE LASER RADIATION
WHEN OPEN AND INTERLOCKS
DEFEATED.
AVOID EXPOSURE TO BEAM



This product contains a low power Laser Device.

FCC INFORMATION

This equipment has been tested and found to comply with the limits for a Class B digital device, pursuant to Part 15 of the FCC Rules. These limits are designed to provide reasonable protection against harmful interference in a residential installation. This equipment generates, uses, and can radiate radio frequency energy and, if not installed and used in accordance with the instructions, may cause harmful interference to radio communications. However, there is no guarantee that interference will not occur in a particular installation. If this equipment does cause harmful interference to radio or television reception, which can be determined by turning the equipment off and on, the user is encouraged to try to correct the interference by one or more of the following measures:

- Reorient or relocate the receiving antenna.
- Increase the separation between the equipment and receiver.
- Connect the equipment into an outlet on a circuit different from that to which the receiver is connected.
- Consult the dealer or an experienced radio/TV technician for help.

This device complies with Part 15 of the FCC Rules. Operation is subject to the following two conditions:

- (1) This device may not cause harmful interference, and
- (2) This device must accept any interference received, including interference that may cause undesired operation.



PREPARATION FOR USE

UNPACKING AND SET UP

- Carefully remove the unit from the carton and remove all packing materials from the unit.
- The AC power cord is separate from the main unit. Make sure that the power cord is not accidentally thrown away with the packing materials.
- Carefully remove any small strips of tape which may have been used to keep the CD and Cassette doors closed during shipment.
- Open the CD compartment by lifting the “**OPEN**” tab on top panel. Inside the CD compartment you will see a white transit card which is used to prevent the laser pick-up from moving during shipment. Carefully remove this card and close the CD compartment door.
- Please save the carton and packing materials in the event that your unit ever needs to be returned for service. The original carton and packing materials are the only way to protect the unit from damage during shipment.
- Unwind the FM lead wire antenna and extend it to its full length.
- Remove the twist-tie from the AC power cord and extend it to its full length.



POWER SOURCE

This system is designed to operate on normal 120V 60 Hz AC house current only. Attempting to operate this system from any other power source may cause damage to the system, and such damage is not covered by your warranty.

Plug the small end to AC socket on back panel, and Connect the AC plug to your AC outlet. See illustration below.

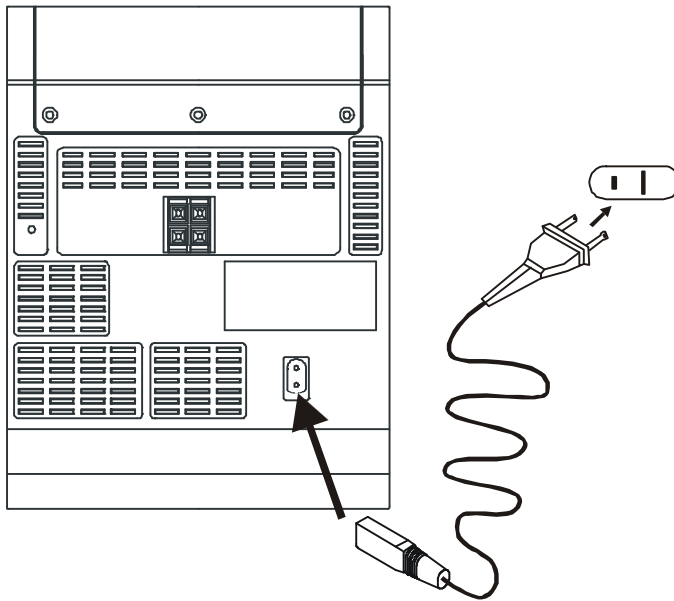

NOTE: This unit has a polarized AC plug with one wide blade and one narrow blade. This plug will only fit into a matching polarized AC outlet. This is a safety feature to reduce the possibility of electric shock. If this plug will not fit in your AC outlet, you probably have an outdated non-polarized outlet. You should have your outdated outlet changed by a qualified, licensed electrician. Do not file the wide blade on the plug, or use an adapter to make the plug fit into your outlet. This defeats the safety feature and could expose you to electric shock.

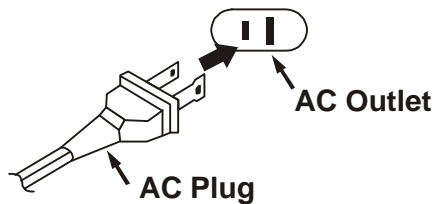



SPEAKER CONNECTION

Connect each speaker to the corresponding speaker terminals on the back panel of the main unit. Make sure that:

- The left speaker is connected to the (L) left pair of speaker terminals, and the right speaker to the (R) right pair of speaker terminals.

Also make sure that the speaker wires are correctly connected:

- That the red wires are connected to the red (+) terminals, and the black wires to the black (-) terminals.

Depress the plastic lever to open the terminal, insert the bare end of the speaker wire into the opening and release.

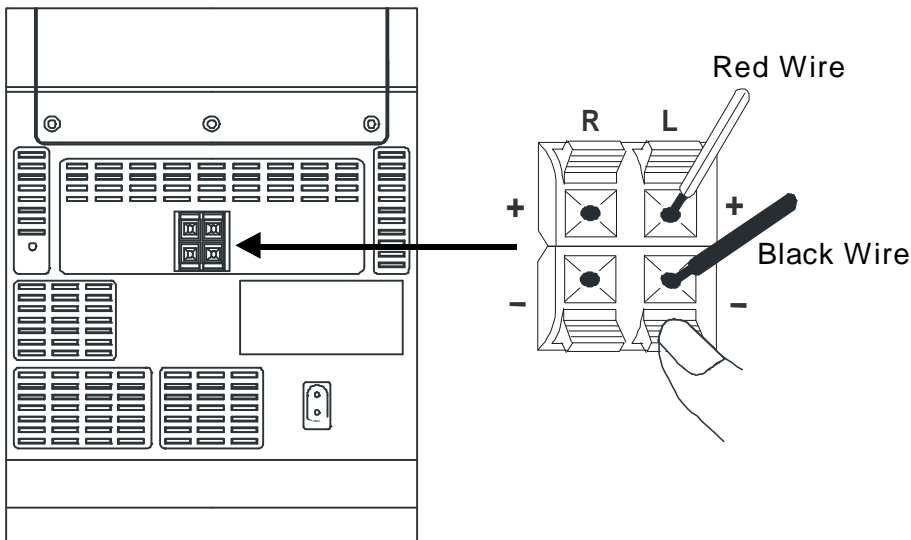

PROTECT YOUR FURNITURE

This model is equipped with non-skid rubber 'feet' to prevent the product from moving when you operate the controls. These 'feet' are made from non-migrating rubber material specially formulated to avoid leaving any marks or stains on your furniture. However certain types of oil based furniture polishes, wood preservatives, or cleaning sprays may cause the rubber 'feet' to soften, and leave marks or a rubber residue on the furniture. To prevent any damage to your furniture we strongly recommend that you purchase small self-adhesive felt pads, available at hardware stores and home improvement centers everywhere, and apply these pads to the bottom of the rubber 'feet' before you place the product on fine wooden furniture.



LOCATION OF CONTROLS AND INDICATORS

FRONT PANEL

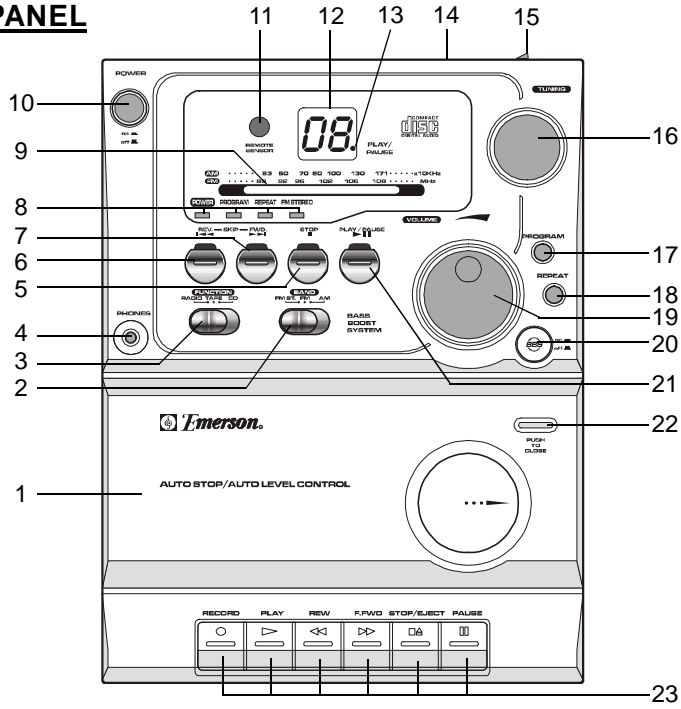

BACK PANEL

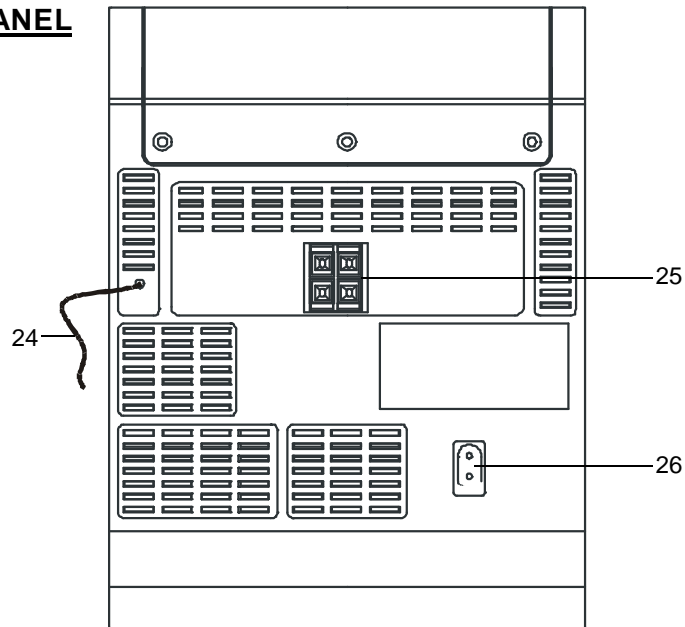



FRONT PANEL

- 1.) Cassette Door.
- 2.) **BAND (FM ST. / FM / AM)** Selector Switch.
- 3.) **FUNCTION (RADIO / TAPE / CD)** Selector Switch.
- 4.) **PHONES** Jack.
- 5.) CD **STOP** Button.
- 6.) CD **SKIP REV** ◀◀ Button.
- 7.) CD **SKIP FWD** ▶▶ Button.
- 8.) **POWER 'On' / PROGRAM / REPEAT / FM STEREO** LED Indicators.
- 9.) Tuning Dial.
- 10.) **POWER ON** ☐ / **OFF** ■ Button.
- 11.) **REMOTE SENSOR**.
- 12.) CD Track Number Display.
- 13.) CD **PLAY / PAUSE** Indicator.
- 14.) CD Door.
- 15.) CD Door **OPEN** tab.
- 16.) **TUNING** Control.
- 17.) CD **PROGRAM** Button.
- 18.) CD **REPEAT** Button.
- 19.) **VOLUME** Control.
- 20.) **BBS** (Bass Boost) **ON** ☐ / **OFF** ■ Button.
- 21.) CD **PLAY/PAUSE** ▶|| Button.
- 22.) Cassette Door **PUSH TO CLOSE** Position.
- 23.) Cassette Control Keys
RECORD ● / **PLAY** ▶ / **REW** ◀◀ / **F. FWD** ▶▶ / **STOP-EJECT** ■▲ / **PAUSE** ||.

BACK PANEL

- 24.) External FM Wire Antenna.
- 25.) **SPEAKER** Terminals.
- 26.) AC Cord Socket.



REMOTE CONTROL (CD Operations Only)

- 1.) **SKIP REV** ◀◀ Button.
- 2.) **SKIP FWD** ▶▶ Button.
- 3.) **PLAY / PAUSE** ▶|| Button.
- 4.) **STOP** ■ Button.
- 5.) **SEARCH** Forward ▶▶▶ Button.
- 6.) **SEARCH** Reverse ◀◀◀ Button.
- 7.) **PROG** (Program) Button.
- 8.) **REPEAT** Button
- 9.) Battery Compartment.
(Back Cabinet)

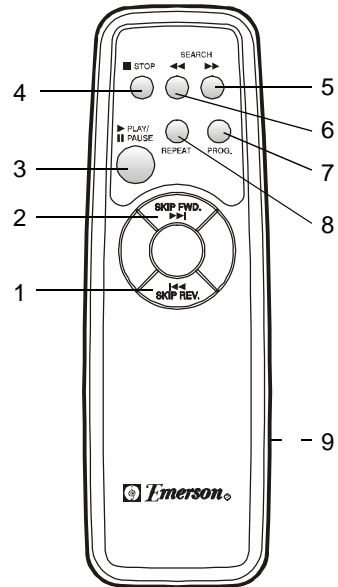

BATTERY INSTALLATION

- 1.) Open the battery door on the back of the remote control by sliding the battery door in the direction of the arrow.

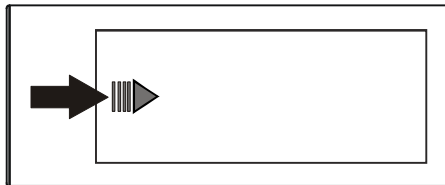

- 2.) Insert two "AA" alkaline batteries (not included) into the battery compartment. Be sure the batteries are inserted according to the polarity markings inside the battery compartment.

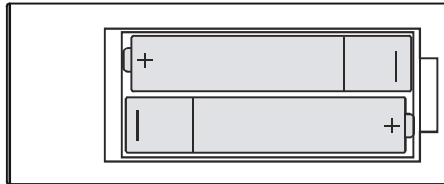

- 3.) Replace the battery door.



BATTERY REPLACEMENT

When the batteries become too weak, the operating distance of the remote control is greatly reduced and you will need to replace the batteries.

USING THE REMOTE CONTROL CORRECTLY

- Point the remote control at the **REMOTE SENSOR**.
- The functions of the buttons on the remote control are the same as the corresponding controls on the main unit.
- When there is a strong ambient light source, the performance of the infrared Remote Sensor may be degraded, causing unreliable operation.
- The maximum effective distance for remote control operation is about 15 feet.



BATTERY PRECAUTIONS

Follow these precautions when using batteries in this device:

- 1.) Use only the size and type of batteries specified.
- 2.) Be sure to follow the correct polarity when installing the batteries as indicated in the battery compartment. Reversed batteries may cause damage to the device.
- 3.) Do not mix different types of batteries together (e.g. Alkaline and Carbon-Zinc) or old batteries with fresh ones.
- 4.) If the device is not to be used for a long period of time, remove the batteries to prevent damage or injury from possible battery leakage.
- 5.) Do not try to recharge batteries not intended to be recharged; they can overheat and rupture. (Follow battery manufacturer's directions.)

OPERATING INSTRUCTIONS

BBS (Bass Boost) Switch

This system includes a **BBS** (Bass Boost) button that provides increased bass response, especially at lower listening levels. Press the **BBS** button once to turn the Bass Boost circuit 'ON '. Press the **BBS** button again to turn the Bass Boost circuit 'OFF '.

Note: If you experience any distortion when listening at high volume levels, turn the Bass Boost 'off'.

LISTENING TO THE RADIO

- Make sure that the FM Wire antenna is extended to its full length.

- 1.) Press the **POWER** button to turn the unit "ON ". The **POWER** indicator comes 'on'.

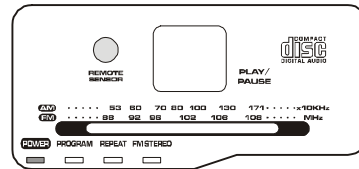

- 2.) Slide the **FUNCTION** selector switch to **RADIO**.
- 3.) Slide the **BAND** switch the **FM ST.**, **FM** or **AM** position to select the radio band as desired.



- 4.) Turn the **TUNING** control to tune to the desired radio station.

Note:

*If you tune to an FM Stereo station and the **BAND** selector is set to **FM ST.**, the **FM STEREO** indicator will light.*

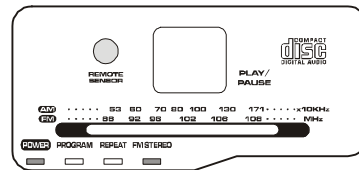

*If the FM reception is noisy or weak you may be able to improve it by sliding the **BAND** selector to the **FM** (Mono) position, however the sound will no longer be in stereo.*

- 5.) Adjust the **VOLUME** and **BBS** controls as desired.
- 6.) When you are finished listening press the **POWER** button to the "OFF " position. All indicators go 'off'



HINTS FOR BETTER RECEPTION

FM: The FM lead wire antenna on the back panel should be extended to its full length. You may also have to vary the direction of this antenna until you find the position that provides the best reception.

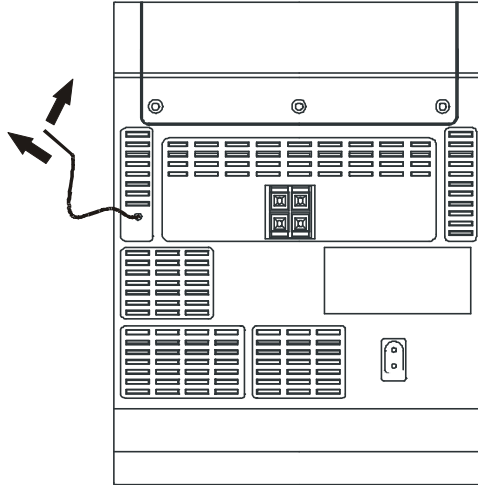

AM: The AM bar antenna is inside the cabinet of the main unit. You may need to change the position of the main unit until you find the position that provides the best reception for your favorite AM stations.

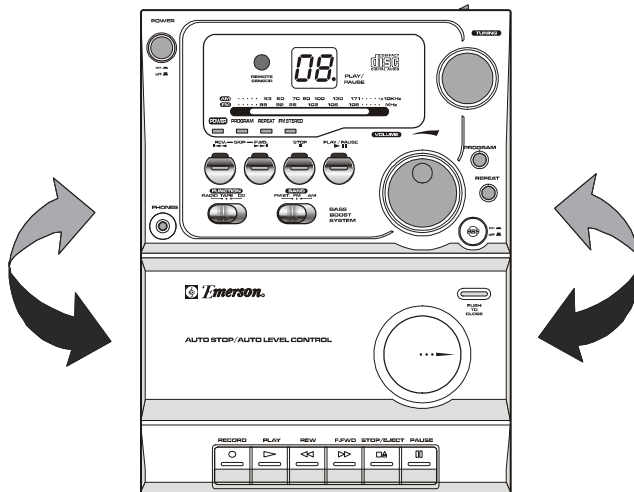



PLAYING COMPACT DISCS

NOTE: Although this portable CD player can read CD-R and CD-RW discs, in addition to normal CDs, the playability of CD-R and CD-RW discs may be effected by the type of software that was used to create the discs, as well as the quality and condition of the blank media you are using. 100% playability cannot be guaranteed. This is not an indication of a problem with the player.

NORMAL PLAYBACK

1.) Press the **POWER** button to turn the unit “ON ”. The **POWER** indicator comes ‘on’.

2.) Slide the **FUNCTION** selector switch to **CD** position.

FUNCTION
RADIO TAPE CD



3.) Open the CD door by lifting the **OPEN** tab on top of CD door. If you have not already removed the white transit card from the CD player, please remove it now.

4.) Place your CD on the center spindle with the printed label side facing up. Close the CD door. The player will read the Table of Contents and the display will show the total number of tracks on the disc.

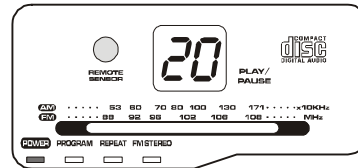

If the disc is damaged or up side down, display shows “- -”.

5.) Press the CD **PLAY/PAUSE**  button to begin playback on Track 1. The **PLAY/PAUSE** “Dot” Indicator appears in the display.

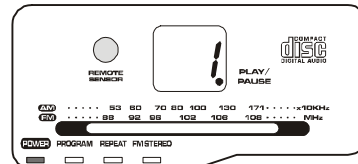

6.) Adjust the **VOLUME** and **BBS** controls as desired.

7.) Playback will continue until the end of the disc. When the disc ends the display again shows the total number of tracks on the disc. You may also stop playback at any time by pressing the CD **STOP**  button.

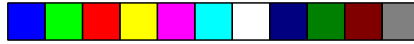

Pause Control

To pause momentarily during playback press the CD **PLAY/PAUSE** ►|| button again. Playback stops but the disc continues to spin and the **PLAY** indicator flashes. Press the CD **PLAY/PAUSE** ►|| button once more to cancel Pause and resume playback. The **PLAY/PAUSE** indicator stops flashing.

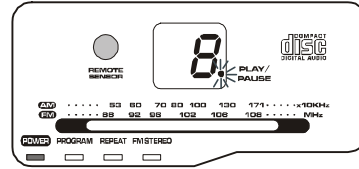

Skipping Tracks and High Speed Music Search

During CD Playback, repeatedly press the **SKIP FWD** ►► or **SKIP REV** ◀◀ buttons to skip to higher or lower number tracks. When the desired track number appears on the display release the buttons and playback will begin on the desired track.

To rapidly search forward or back within a track to locate a specific musical passage, depress and hold either the ►► / ◀◀ buttons on main unit, or ◀◀ / ►► buttons on remote control. The player will move forward or backward at high speed as long as the buttons are depressed. When you hear the desired passage release the buttons. Normal playback will resume at that point.

Repeat Playback

This feature allows you to continuously repeat a single track or the entire disc.

To Repeat A Single Track

Press the **REPEAT** button once. The **REPEAT** indicator flashes. Press the ►► or ◀◀ buttons to select the desired track, then press the CD **PLAY/PAUSE** ►|| button to begin Repeat Playback of the selected track.

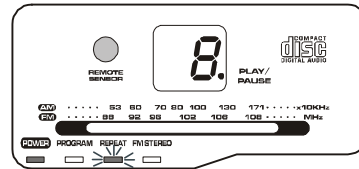

To Repeat The Entire Disc

Press the **REPEAT** button twice. The **REPEAT** indicator remains 'on'. Press the CD **PLAY/PAUSE** ►|| button to begin Repeat Playback of the entire disc.

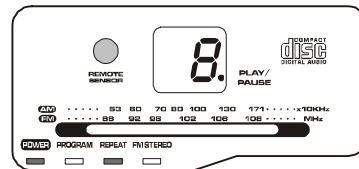

To cancel Repeat Playback press the **REPEAT** button until the **REPEAT** Indicator goes 'off'. Repeat Playback is also canceled by pressing the **STOP** ■ button, or setting the **FUNCTION** selector to the **TAPE** or **RADIO** position.

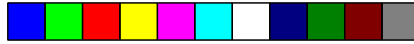

PROGRAMMED PLAYBACK

This feature allows you to program up to 20 tracks on a disc for playback in any desired order.

Note: You cannot program tracks while a disc is playing. If the disc is playing press the **STOP** ■ button first before beginning the programming steps below:

- 1.) Press the **PROGRAM** button to enter the Program Mode. The **PROGRAM** indicator and Program Number '0' flash.

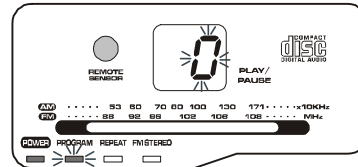

- 2.) Press the **SKIP** ►► or ◄◄ buttons to select the first track number you wish to enter in the program memory.

Example: Track Number 8.

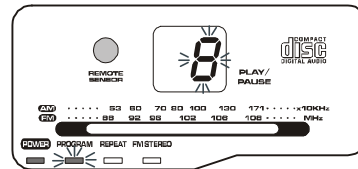

- 3.) When the desired track number appears on the display, press the **PROGRAM** button again to enter that track in memory. The Program Number display returns to "0".

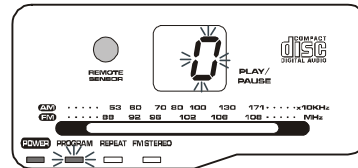

- 4.) Repeat Steps 2-3, selecting a different track number each time until you have entered up to 20 tracks in the program memory.

Note: You may program the same track number to play multiple times in the program sequence if desired. When programmed track is full, "– –" flashes in the display.

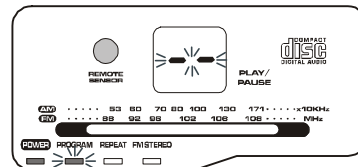

- 5.) Press the **PLAY/PAUSE** ►► button to begin Programmed Playback. The **PROGRAM** indicator flashes. Playback will begin with the first track you programmed and will continue until the last programmed track has played.

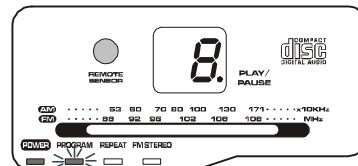



6.) After the last track has played the player stops and the display shows the total number of tracks on the disc. However the program sequence remains in the memory.

Press the **PROGRAM** button, then the **PLAY/PAUSE** ►|| button to play the programmed sequence again.

7.) To cancel the programmed sequence from the memory press the **STOP** ■ button while in programming mode.

The programmed sequence may also be canceled by removing the disc, changing function to **TAPE**, **RADIO**, or shutting the system 'off'.

Program Repeat Playback

You can use the Program and Repeat features together to continuously repeat a programmed sequence of tracks.

First, program the desired tracks according to Steps 1 through 5 on page 14.

When Programmed Playback begins press the **REPEAT** button twice to activate the All Tracks Repeat feature.

The **REPEAT** Indicator lights and all the tracks in your programmed sequence will be repeated continuously.

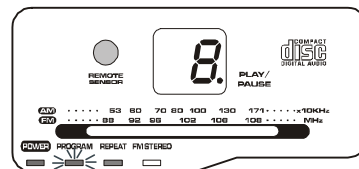

To cancel Programmed Repeat Playback press the **STOP** ■ button until both the **PROGRAM** and **REPEAT** Indicators go 'Off'.

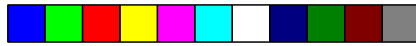

PLAYING CASSETTE TAPES

1.) Press the **POWER** button to turn the unit “**ON** ”. The **POWER** indicator comes ‘on’.

2.) Slide the **FUNCTION** selector switch to **TAPE** position.





3.) Open the cassette door by pressing the **STOP/EJECT**  key.

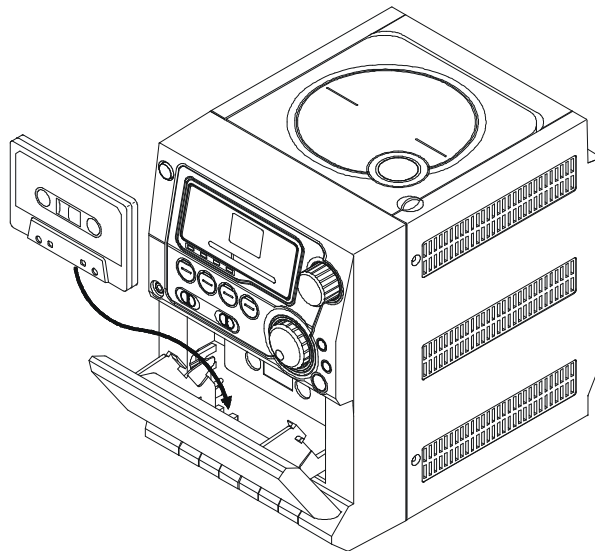

4.) Place a pre-recorded cassette tape into the slots on the inside of the door with the exposed tape facing down and the full reel on the left side.



5.) Press the cassette **PLAY**  key to begin playback.

6.) Adjust the **VOLUME** and **BBS** controls as desired.

7.) To advance the tape rapidly press the **F. FWD**  key. To stop the tape before it ends press the **STOP/EJECT**  key.

8.) To rewind the tape rapidly press the **REW**  key. To stop the tape before it ends press the **STOP/EJECT**  key.



- 9.) When the tape ends the Automatic Stop System releases the **PLAY ►** key and shuts off the tape motor. You may then open the cassette door, remove your tape, turn it over and play the other side if desired.
- 10.) When you are finished listening stop the tape, open the door, remove the tape and close the door. If you are playing a tape and then switch to the **RADIO** or **CD** function be sure to press **STOP/EJECT ■▲** key to disengage the tape mechanism. This prevents excess wear and tear on the mechanism.

IMPORTANT:

*Always press the **STOP/EJECT ■▲** key to shut off the tape motor before opening the cassette door to remove your tape. The Automatic Stop System does not function in the Fast Forward ►► and Rewind ◀◀ modes. When the tape ends in the Fast Forward ►► and Rewind ◀◀ modes the motor continues to run. You must press the **STOP/EJECT ■▲** key to shut off the motor before opening the door to remove your tape.*





MAKING A TAPE RECORDING

This model allows you to make tape recordings directly from the CD player, or the radio.

- Refer to “**PLAYING COMPACT DISCS**” if necessary to operate the CD player.
 - Refer to “**LISTENING TO THE RADIO**” if necessary to tune in the station you wish to record from radio.
- 1.) Press the **STOP/EJECT** ■▲ key to open the cassette door.
 - 2.) Insert a good quality blank cassette tape into the slots on the cassette door with the open end facing down and the full reel on the left. Use normal tape only. Do not use tape identified as “CrO₂” (Chrome) or “Metal” tape formulations. For best results use tapes of 60 minutes (C-60) or less. Do not use 90 minute or 120 minute tapes as these thinner tapes are more likely to jam in the mechanism.
 - 3.) Close the cassette door.
 - 4.) When you are ready to start recording press the **RECORD** ● key. The **PLAY** ► key will also engage. The CD you are playing, or radio program you selected will be recorded directly on to the tape.
 - 5.) Press the **PAUSE** II key during recording to stop the tape temporarily and avoid recording unwanted material such as radio commercials.
 - 6.) When you have finished recording press the **STOP/EJECT** ■▲ key to stop and remove the tape.

Automatic Recording Volume Level Control

This unit has an Automatic Level Control (ALC) circuit which controls the recording volume level and prevents overloaded and distorted recordings. The **VOLUME** and **BBS** controls have no effect on recording volume level. You may change the **VOLUME** control setting during the recording or even reduce the volume level to “Minimum”. This will not effect the level of the recording.



STEREO HEADPHONE JACK

Connect a set of stereo headphones (not included) with a 3.5mm mini plug to the **PHONES** jack on front panel, for private listening without disturbing others.

Before putting on the headphones reduce the **VOLUME** control to a low level, then put the headphones on and gradually increase the **VOLUME** control to a comfortable listening level.

The built in speakers are automatically disconnected when headphones are connected to the **PHONES** jack.





CARE AND MAINTENANCE

ABOUT CASSETTE TAPES

Whenever you record on a cassette any previously recorded material is erased as the new material is recorded. To prevent you from accidentally erasing material which you wish to save, blank cassettes are equipped with erase prevention tabs for each side of the tape. If the erase prevention tab for side A is removed, you cannot accidentally record on side A. The record key cannot be depressed if the erase prevention tab on the cassette has been removed.

To prevent accidental erasing on side A of a cassette use a small screw driver or similar tool to break off the erase prevention tab for side A. This prevents the record key from locking.

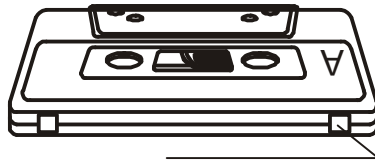

TAB FOR SIDE A
BREAK OUT TO PREVENT RECORDING

If later you do wish to record on side A of the cassette, cover the tab opening with a piece of cellophane tape. This will allow the record key to function again.

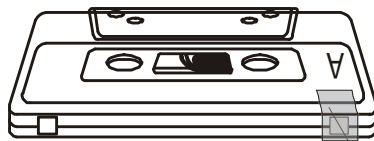

COVER OPENING WITH TAPE
IN ORDER TO RECORD AGAIN.



CASSETTE CARE

Two common causes of trouble experienced when using cassettes are:

- 1.) Tape jamming — Leading to uneven speed in playback, and
- 2.) Tape tangling — Where the tape wraps itself around vital parts of the mechanism.

To reduce the likelihood of these problems occurring, the following precautions should be observed:

- Check that there are no loose layers of tape visible through the cassette center window (see Fig. 1). Take up any loose layers, using a pencil or hexagonal barrelled ballpoint pen, before inserting the cassette into the machine (see Fig. 2).

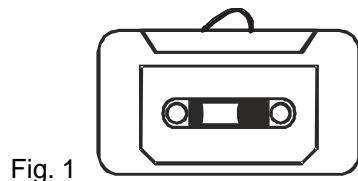

Fig. 1

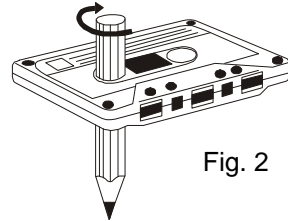

Fig. 2

- If the cassette feels “tight” while performing operation shown (see Fig. 2), the tape may be jamming due to “ridges” formed in the winding of the tape (visible through the center window). These may be removed, in most cases, by fast winding of the cassette from one end to the other and back again.
- Use only well-known brands of tape. Avoid use of C-120 cassettes.

Furthermore, do not expose cassettes to direct sunlight, dust or oil, and do not touch the tape surfaces.



HEAD CLEANING

The tape heads, pinch roller and capstan require periodic cleaning. This removes particles of the metal oxide coating that wear off the tape and accumulate on these parts and impair performance. Turn off the power, press the **STOP/EJECT** ■▲ key to open the cassette door, and press the **PLAY** ► key. Clean the tape heads, pinch roller and capstan with a soft cloth or cotton pad dampened in isopropyl alcohol or special tape head cleaner.

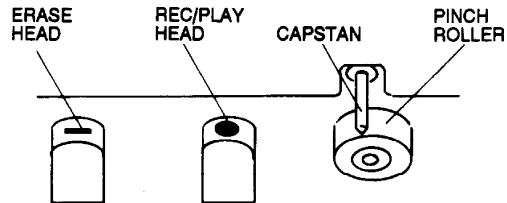



COMPACT DISC CARE

- To remove a disc from its storage case, press down on the center of the case and lift the disc out, holding it carefully by the edges.



- Fingerprints and dust should be carefully wiped off the disc's recorded surface with a soft cloth. Unlike conventional records, compact discs have no grooves to collect dust and microscopic debris, so gently wiping with a soft cloth should remove most particles. Wipe in a straight line from the inside to the outside of the disc. Small dust particles and light stains will have absolutely no effect on reproduction quality.

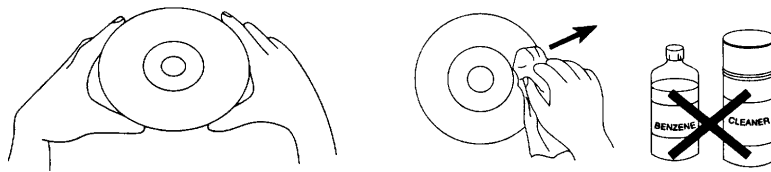

- Clean the disc periodically with a soft, lint-free, dry cloth. Never use detergents or abrasive cleaners to clean the disc. If necessary, use a CD cleaning kit.
- Never write on or affix labels to the surface of compact discs.

CARE OF THE CABINET

If the cabinet becomes dusty wipe it with a soft dry dust cloth. Do not use any wax, polish sprays, or abrasive cleaners on the cabinet.

CAUTION

Never allow any water or other liquids to get inside the unit while cleaning.



LIMITED WARRANTY

Emerson Radio Corp. warrants manufacturing defects in original material, including original parts and workmanship, under normal use and conditions, for a period of ninety (90) days from the date of original purchase in the U.S. With your dated proof of purchase, we will provide repair service at no charge for labor and parts at an authorized Depot Repair Facility, or replace the product in our discretion. For repair or replacement, pack your unit in a padded box, enclose your check or money order payable to Emerson Radio Corp. in the amount of \$9.00 (not required by California residents) to cover shipping and handling costs, and enclose a copy of your proof of purchase. Send your unit to:

Emerson Radio Corp.
1901 Diplomat Drive.
Farmers Branch, TX 75234.

This warranty does not cover damage from negligence, misuse, abuse, accident, failure to follow operating instructions, commercial use, rental, repairs by an unauthorized facility, or products purchased, used, serviced or damaged outside of the United States.

THIS WARRANTY GIVES YOU SPECIFIC LEGAL RIGHTS, AND YOU MAY ALSO HAVE OTHER RIGHTS WHICH VARY FROM STATE TO STATE.

AU898M



TO FIND THE LOCATION AND PHONE NUMBER OF YOUR NEAREST SERVICE CENTER PERMITTED TO PERFORM WARRANTY...

CALL TOLL FREE: 1-800-695-0098

FOR ADDITIONAL SET-UP OR OPERATING ASSISTANCE
PLEASE CALL:
1-800-898-9020

FOR CUSTOMER SERVICE, PLEASE WRITE TO:
Emerson Radio Corp.
Consumer Affairs Dept.
1901 Diplomat Drive,
Farmers Branch, TX 75234.





EMERSON
Part No. : 16-2946
403-01

Printed in China